

**SH/MH-60**

AVAILABILITY DELIVERED®

ASI is the only Authorized Maintenance Center and Distributor for the Triumph Tail Bumper System utilized on the SH/MH-60 Seahawk.



Primarily consisting of a drag link, an outer cylinder, a moveable inner piston assembly and a skid pad, the Tail Bumper Assembly is fixed and mounted on the underside of the tail pylon. This system prevents the stabilator from striking the ground when landing with nose-high attitudes protecting the tail of the helicopter.

AS9100 certified



SH/MH-60 TAIL BUMPER SYSTEM

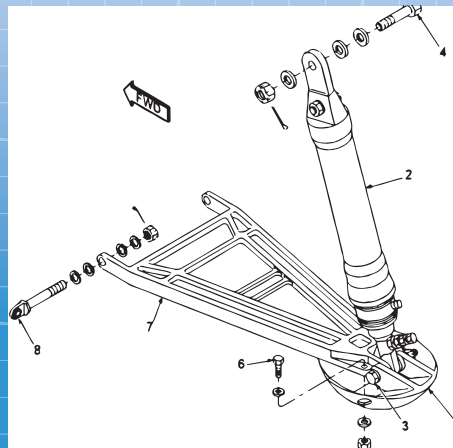
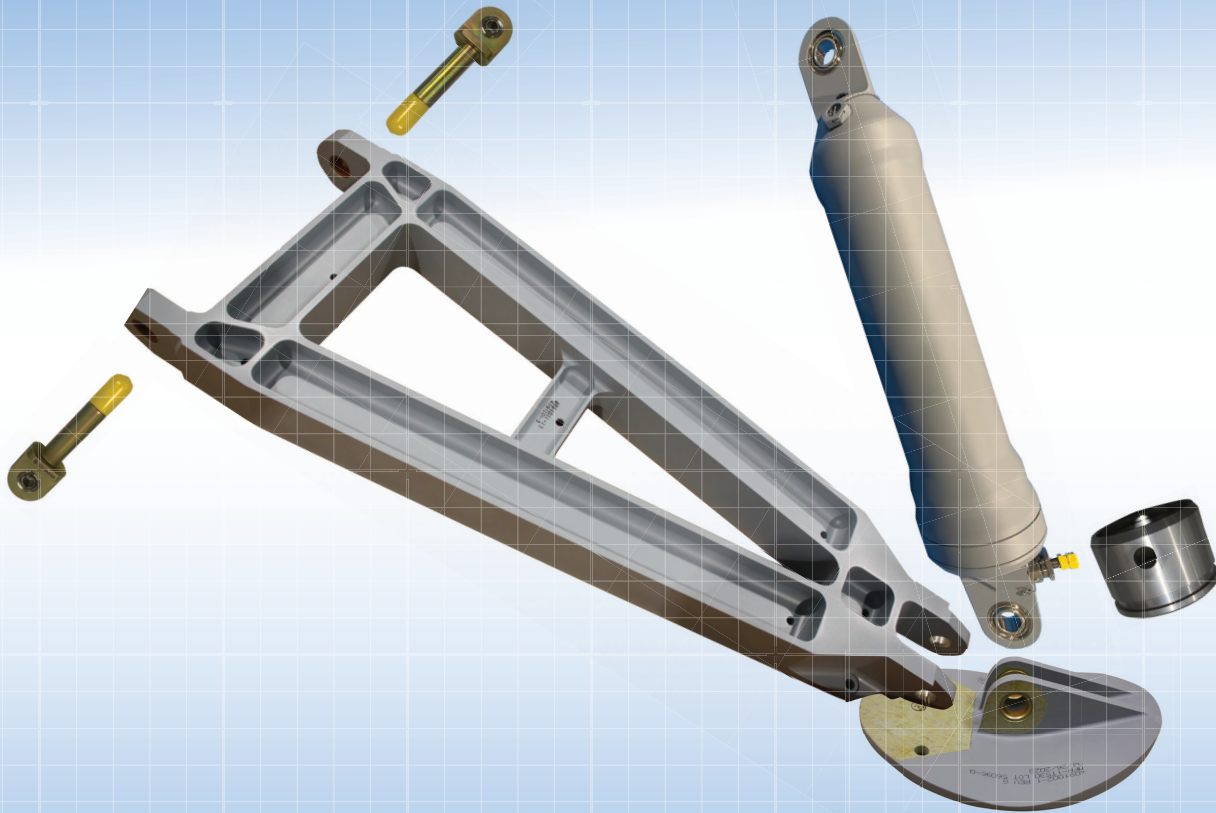

Part Number	Description
OMP4091-3 / -5	TAIL BUMPER ASSY
4091001-3	DRAG LINK ASSY
4091002-1	SKID PAD ASSY
4091003-3	WASHER
4091004-1	BOLT ASSY
OMP4092-3 / -5	OLEO SHOCK STRUT
4091101-1	PLATE, INSTRUCTION TAIL BUMPER
4092003-1	STRAP, RETAINER TAIL BUMPER ST
4092004-1	PIN,RETAINING TAIL BUMPER STRT
4092005-1	GLAND, TAIL BUMPER STRUT ASSY
4092007-1	RESTRICTOR TAIL BUMPER STRUT
4092008-1	SPACER, TAIL BUMPER STRUT ASSY
4092009-1	PIN, TAIL BUMPER STRUT ASSY
4092010-1	BEARING,SPLIT TAIL BUMPER STRUT
4092011-3	METERING PIN TAIL BUMPER STRUT
4092012-1	SPACER, TAIL BUMPER STRUT ASSY
4092001-1	CYLINDER ASSY TAIL BUMPER STRUT
4092002-3	PISTON ASSY
3966005-1	BUTTON
4092006-1	RING,DAMPNER TAIL BUMPER STRUT
4092013-1	PISTON,FLOATING

